

INSTRUCTION MANUAL

FOR

WJ-8718/SMO

INTRODUCTION

The WJ-8718/SMO is an option to the WJ-8718 HF Receiver. This Instruction Manual is a supplement to the 8718 HF Receiver Instruction Manual and is to be utilized in conjunction with that manual.

WATKINS-JOHNSON COMPANY

700 QUINCE ORCHARD ROAD

GAITHERSBURG, MARYLAND 20760

January 1979: D. J. L.

1.1 FUNCTIONAL DESCRIPTION

The Signal Monitor Output (SMO) option for the WJ-8718 HF Receiver provides a rear panel output of 455 kHz to drive an external Signal Monitor or Spectrum Display unit such as the WJ-9188A Monitor. The Signal Monitor display can be used to determine the frequency amplitude and type of the received signal. The maximum useable Signal Monitor sweep width of this output is limited to 15 kHz on each side of the receiver tuned frequency.

1.2 ELECTRICAL CHARACTERISTICS

The 455 kHz signal is produced through the extraction of the 10.7 MHz signal from the Input Converter of the WJ-8718 HF Receiver. The circuitry of the SMO option then converts this signal to 455 kHz with a nominal gain of 6-8 dB.

The SMO option consists of two modules: a Matching Network and a Converter. The Matching Network is electrically connected to the receiver's Input Converter after the 1st IF filter. From this point the Matching Network extracts the 10.7 MHz signal. After the Input Converter is re-installed in the receiver, this signal is cable connected to the SMO Converter on the bottom of the main deck of the receiver.

The SMO Converter module is powered by a single +15 V supply. In addition to the 10.7 MHz signal, the module receives an 11.155 MHz 3rd LO signal through cable connections to the receiver's 10.7 MHz/455 kHz Converter Assembly. The SMO Converter provides a nominal gain of 6 dB from the receiver RF input to Signal Monitor output.

1.3 MECHANICAL CHARACTERISTICS

See Figures 1-1 through 1-4 for views of the SMO assembly.

The Matching Network printed circuit board A2 is designed to be mounted on the Input Converter Assembly in the receiver. The board is provided with a transistor clip which is fastened directly on the Input Converter transistor (A3Q4) providing the 10.7 MHz signal. An SMC connector on the opposite end of the Matching Network board is slipped through a hole in the receiver chassis wall. One screw secures the assembly.

The SMO Converter assembly is mounted on the bottom of the Receiver deck and is wired to a single +15 V supply. Cables connect the output of the Matching Network to the 11.115 MHz source and to the rear panel connection of the HF Receiver. The assembly is fully enclosed in an aluminum case which is fastened to the receiver chassis by four screws.

1.4 EQUIPMENT SUPPLIED

The SMO assembly consists of two printed circuit boards (A1 and A2) and four cables.

1.5 INSTALLATION

The SMO assembly is available as a factory installed option in a newly purchased WJ-8718 HF Receiver. A receiver purchased without this option should be returned to the factory for installation of the SMO option.

1.6 DETAILED CIRCUIT DESCRIPTION

The SMO assembly is shown in schematic form by Figure 1-8. After mounting the Matching Network (A2) on the receiver's Input Converter Module (A3), the 10.7 MHz signal enters the SMO Converter (A1) at SMO-P3. SMO-P4 inputs the 3rd LO 11.155 MHz signal from pins 13 and 14 of the receiver's module A4A2 through cable connections. The two signals are mixed and the resulting 455 kHz signal at SMO-P1 is cabled to the receiver's rear panel output.

1.6.1 TYPE 796031 MATCHING NETWORK (A2)

Figure 1-6 is the schematic drawing for this assembly. From the collector of A3Q4 (see Figure 1-7) the 10.7 MHz signal enters the Matching Network. C1, C2, L1, and L2 form a single-pole bandpass filter with a center frequency of 10.7 MHz. The selectivity of this network provides for 30 dB additional rejection of the 2nd LO signal.

1.6.2 TYPE 796030 SMO CONVERTER (A1)

The schematic drawing of this module is Figure 1-5. The module contains a 10.7 MHz amplifier, an 11.155 MHz amplifier, a double-balanced mixer, and two filter networks.

The 10.7 MHz signal from the Matching Network is amplified by U1 which provides a gain of 13 dB. The signal is then fed directly to U2, a double-balanced passive type mixer. The mixer's inherent loss (worst case 7 dB) is compensated for by the gain of U1, which provides, in addition, a gain of 6 dB.

The 3rd LO signal of 11.155 MHz is coupled to amplifier Q1 through C2. R2 is a resistive termination for the signal, providing approximately 50 ohms input impedance for the SMO Converter module. R3, R4, and R5 provide base biasing to Q1. The transistor provides amplification of 6-8 dB and also provides buffering action between the mixer and the balance of the receiver circuitry. R7 establishes current through Q1, and R6 provides emitter degeneration to set the gain. L1 is a shunt-fed inductor providing a DC path to the collector of Q1. The output of Q1 is coupled through C6 to a low pass filter

(C7, C8, and L2) which is tuned to 11.155 MHz. The filter transforms the high impedance at the collector of Q1 to a 50 ohm impedance at the mixer.

U2 is a double-balanced passive type mixer which provides a difference frequency of 455 kHz from the 10.7 MHz and 11.155 MHz signals. C9, C10, and L3 form a low pass filter with a cut off frequency of 800 kHz which prevents 2nd LO and 3rd LO frequencies from appearing at the SMO Converter output.

1.7 REPLACEMENT PARTS LIST AND SCHEMATIC DIAGRAMS

The following list of manufacturers, parts list, and schematic diagrams are a supplement for the WJ-8718 HF Receiver instruction manual and are to be used in conjunction with Sections V and VI of this manual.

<u>Mfr. Code</u>	<u>Name and Address</u>
24539	Avantek, Incorporated 3175 Bowers Avenue Santa Clara, CA 95051

1.8 TYPE SMO SIGNAL MONITOR OUTPUT (WJ-8718 HF RECEIVER OPTION)

REF DESIG	DESCRIPTION	QTY. PER ASSY.	MANUFACTURER'S PART NO.	MFR. CODE	RECM. VENDOR
A1	SMO Converter Assembly	1	796030	14632	
A2	Matching Network Assembly	1	796031	14632	
SMO-J1	Connector, Receptacle:BNC Series	1	17300-167-1	14632	
SMO-J2	Connector, Receptacle:SMC Series	1	UG1468/U	00779	
SMO-P1	Connector, Plug: Straight	3	UG1465/U	00779	
SMO-P2	Connector, Plug: Right Angle	1	UG1466/U	00779	
SMO-P3	Same as SMO-P1				
SMO-P4	Same as SMO-P1				
SMO-P5	Same as SMO-P2				
SMO-P6	Connector Housing	1	87499-5	00779	
SMO-W1	Cable Assembly	1	17300-167-1	14632	
SMO-W2	Cable Assembly	1	17300-167-2	14632	
SMO-W3	Cable Assembly	1	17300-167-3	14632	
SMO-W4	Cable Assembly	1	380028-1	14632	

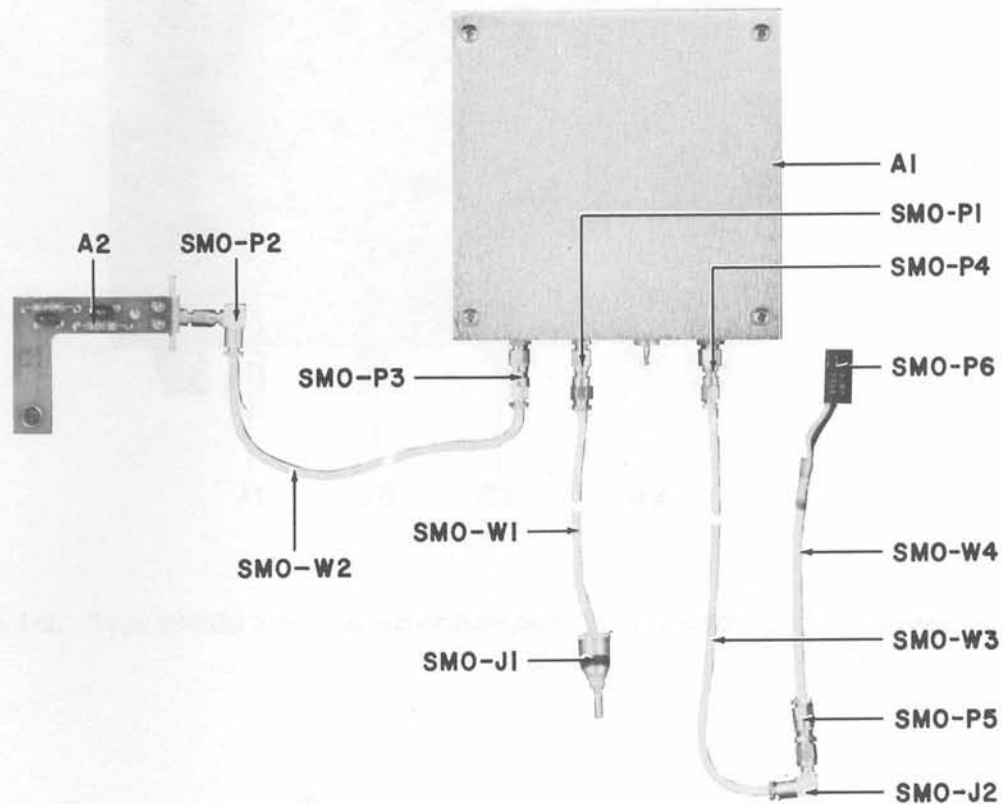

Figure 1-1. Type SMO Signal Monitor Output, Location of Components

1.8.1 TYPE 796030 SMO CONVERTER ASSEMBLY

REF DESIG PREFIX A1

REF DESIG	DESCRIPTION	QTY. PER ASSY.	MANUFACTURER'S PART NO.	MFR. CODE	RECM. VENDOR
A1	SMO Converter	1	280051	14632	
C1	Capacitor, Ceramic, Feedthru: 1000 pF, GMV, 500 V	1	54-794-009-102W	33095	
J1	Connector, Receptacle	3	10-0104-002	19505	
J2	Same as J1				
J3	Same as J1				
MP1	Cover	1	280050-1	14632	

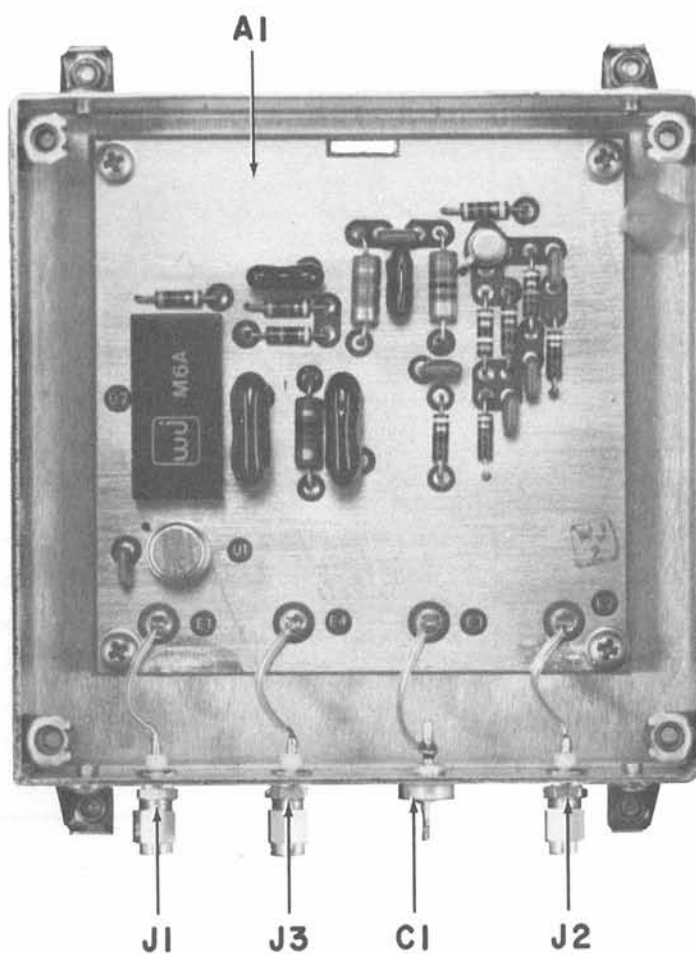

Figure 1-2. Type 796030 SMO Converter Assembly (A1), Location of Components

1.8.1.1 Type 280051 SMO Converter

REF DESIG PREFIX A1A1

REF DESIG	DESCRIPTION	QTY. PER ASSY.	MANUFACTURER'S PART NO.	MFR. CODE	RECM. VENDOR
C1	Capacitor, Ceramic, Disc: 0.1 F, 20%, 50 V	1	34475-1	14632	
C2	Capacitor, Ceramic, Disc: 0.01 F, 20%, 50 V	5	34453-1	14632	
C3 Thru C6	Same as C2				
C7	Capacitor, Mica, Dipped: 68 pF, 2%, 500 V	1	CM05ED680G03	81349	72136
C8	Capacitor, Mica, Dipped: 360 pF, 2%, 500 V	1	CM05FD361G03	81349	72136
C9	Capacitor, Mica, Dipped: 3900 pF, 2%, 500 V	2	CM06FD392G03	81349	72136
C10	Same as C9				
E1	Terminal, Forked	4	140-1941-02-01	71279	
E2	Same as E1				
E3	Same as E1				
E4	Same as E1				
L1	Coll, Fixed: 100 μ H	1	1537-76	99800	
L2	Coll, Fixed: 3.3 μ H	1	1537-24	99800	
L3	Coll, Fixed: 12 μ H	1	1537-38	99800	
Q1	Transistor	1	2N2708	80131	02735
R1	Resistor, Fixed, Composition: 56 Ω , 5%, 1/4 W	2	RCR07G560JS	81349	01121
R2	Same as R1				
R3	Resistor, Fixed, Composition: 1 k Ω , 5%, 1/4 W	1	RCR07G102JS	81349	01121
R4	Resistor, Fixed, Composition: 12 k Ω , 5%, 1/4 W	1	RCR07G123JS	81349	01121
R5	Resistor, Fixed, Composition: 4.7 k Ω , 5%, 1/4 W	1	RCR07G472JS	81349	01121
R6	Resistor, Fixed, Composition: 39 Ω , 5%, 1/4 W	1	RCR07G390JS	81349	01121
R7	Resistor, Fixed, Composition: 560 Ω , 5%, 1/4 W	1	RCR07G561JS	81349	01121
R8	Resistor, Fixed, Composition: 300 Ω , 5%, 1/4 W	2	RCR07G301JS	81349	01121
R9	Resistor, Fixed, Composition: 18 Ω , 5%, 1/4 W	1	RCR07G180JS	81349	01121
R10	Same as R8				
U1	Amplifier	1	GPD402	24539	
U2	Mixer	1	M6A	27956	

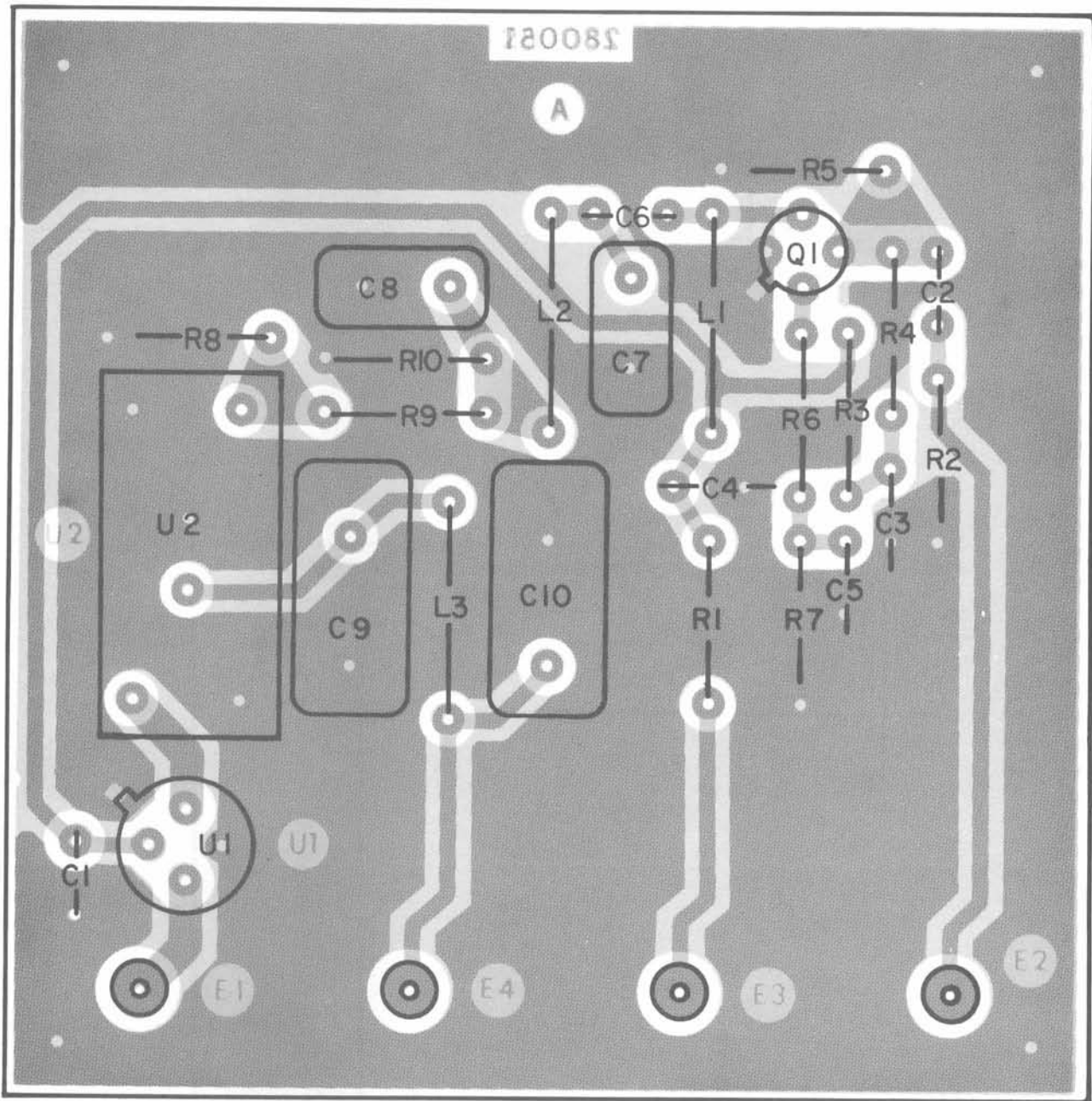

Figure 1-3. Part 280051 SMO Converter (A1A1), Location of Components

TYPE 796031 MATCHING NETWORK ASSEMBLY

REF DESIG PREFIX A2

REF DESIG	DESCRIPTION	QTY. PER ASSY.	MANUFACTURER'S PART NO.	MFR. CODE	RECM. VENDOR
C1	Capacitor, Mica, Dipped: 33 pF, 2%, 500 V	2	CM05ED330G03	81349	72136
C2	Same as C1				
J1	Connector, Receptacle	1	10-0104-002	19505	
L1	Coil, Fixed: 6.8 μ H, 5%	2	1537-32	99800	
L2	Same as L1				
RA1	Heatsink	1	TXB2P032-037B	98978	

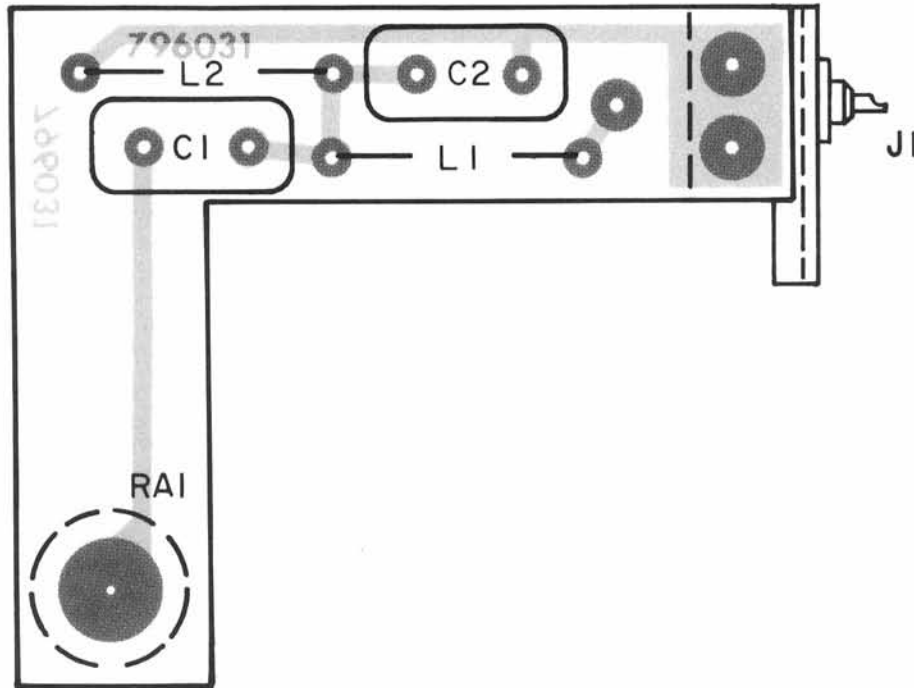
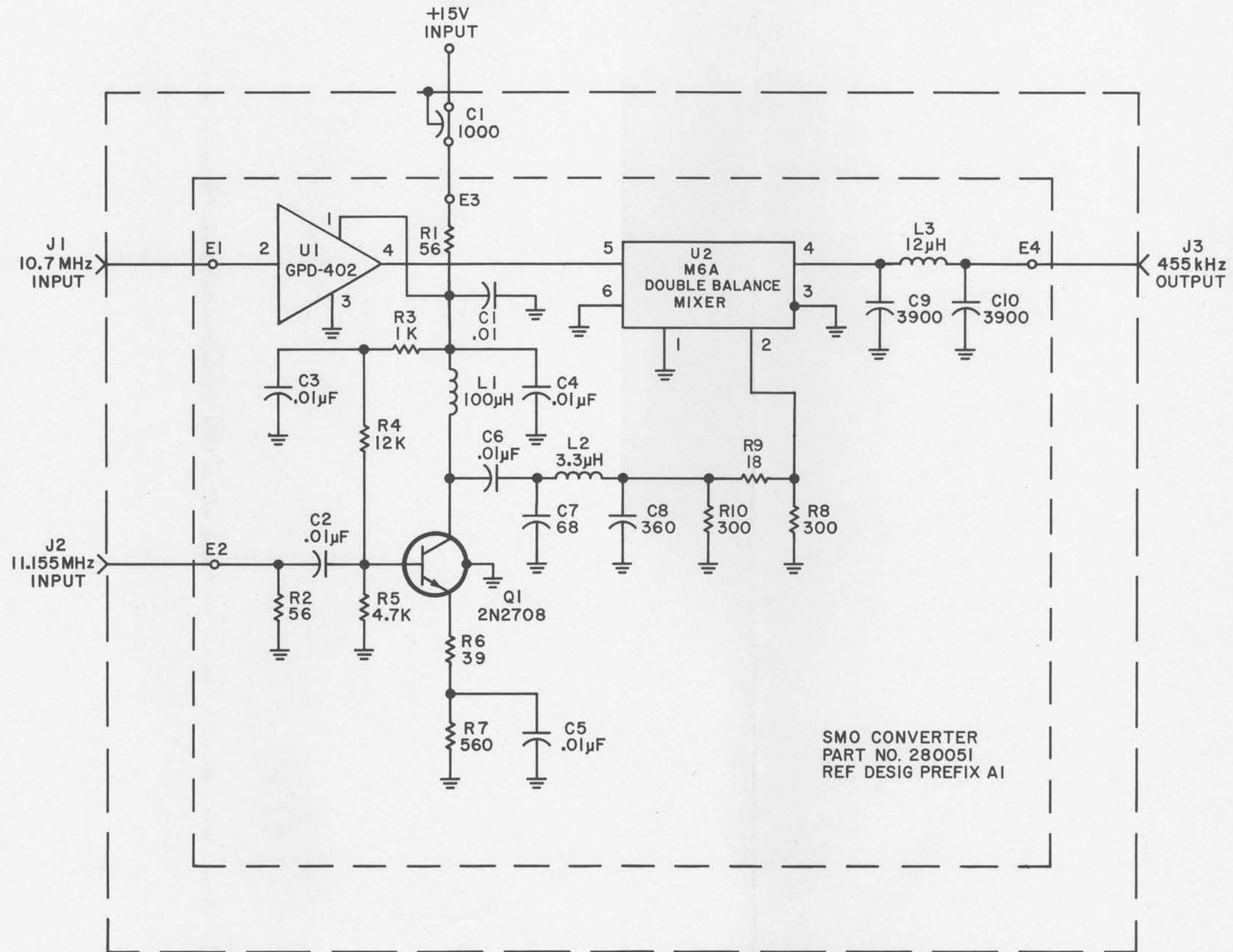

Figure 1-4. Type 796031 Matching Network Assembly (A2), Location of Components



NOTE:
 I. UNLESS OTHERWISE SPECIFIED:
 a) RESISTANCE IS IN OHMS, ±5%, 1/4W.
 b) CAPACITANCE IS IN pF.
 c) INDUCTANCE IS IN μH.

SMO CONVERTER
 PART NO. 280051
 REF DESIG PREFIX A1

Figure 1-5. Type 796030 SMO Converter (A1) Schematic Diagram 380030

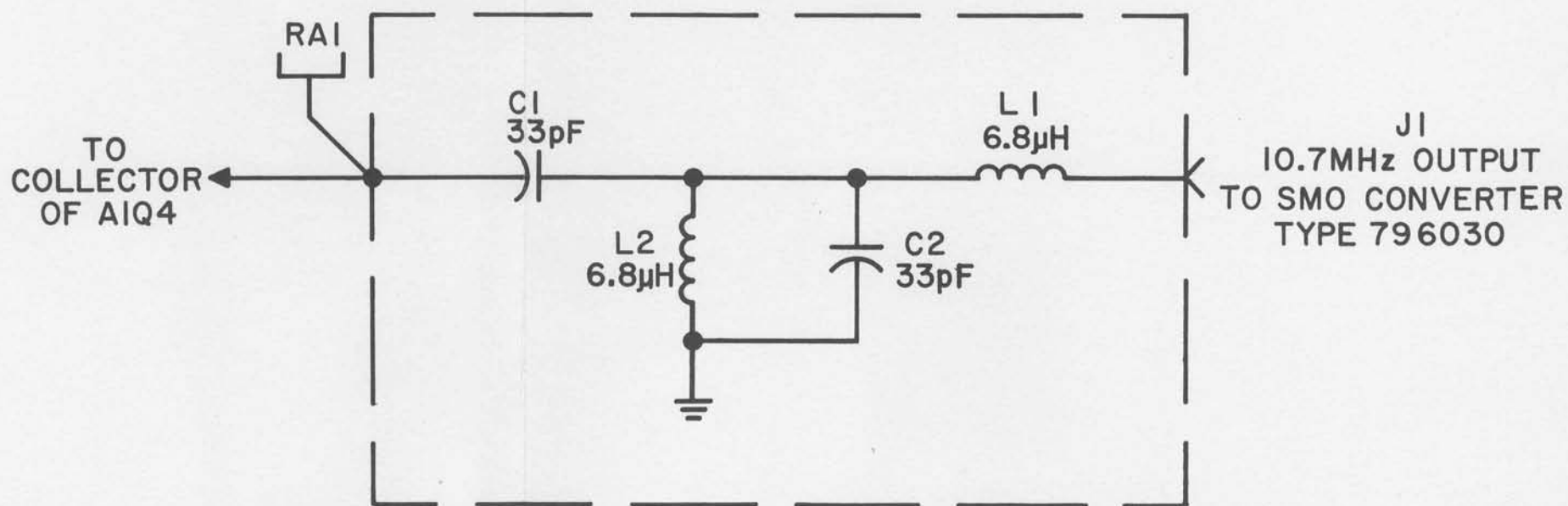
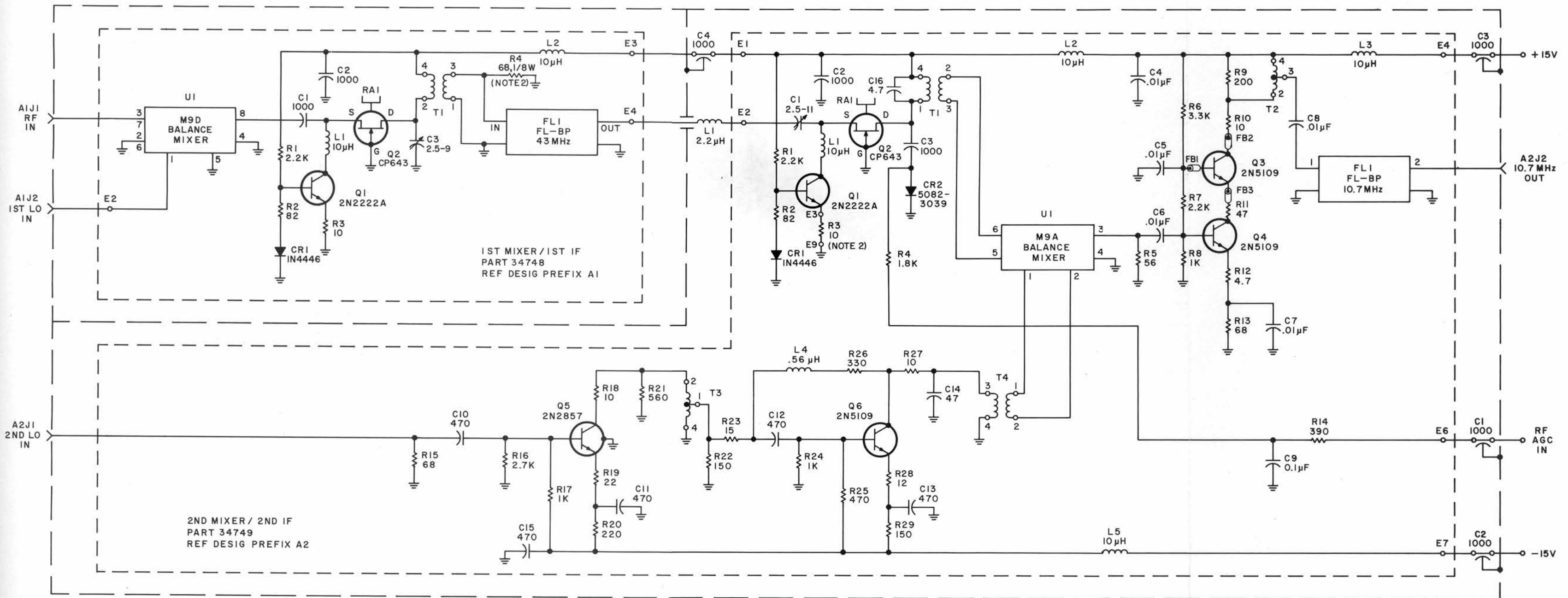

Figure 1-6. Type 796031 Matching Network (A2), Schematic Diagram 280056



NOTES:

1. UNLESS OTHERWISE SPECIFIED:
 - a) RESISTANCE IS IN OHMS, $\pm 5\%$, 1/4 W.
 - b) CAPACITANCE IS IN pF.
2. NOMINAL VALUE ; FINAL VALUE FACTORY SELECTED.

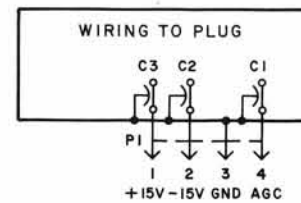

Figure 1-7. Type 791592 Input Converter (A3), Schematic Diagram 51178

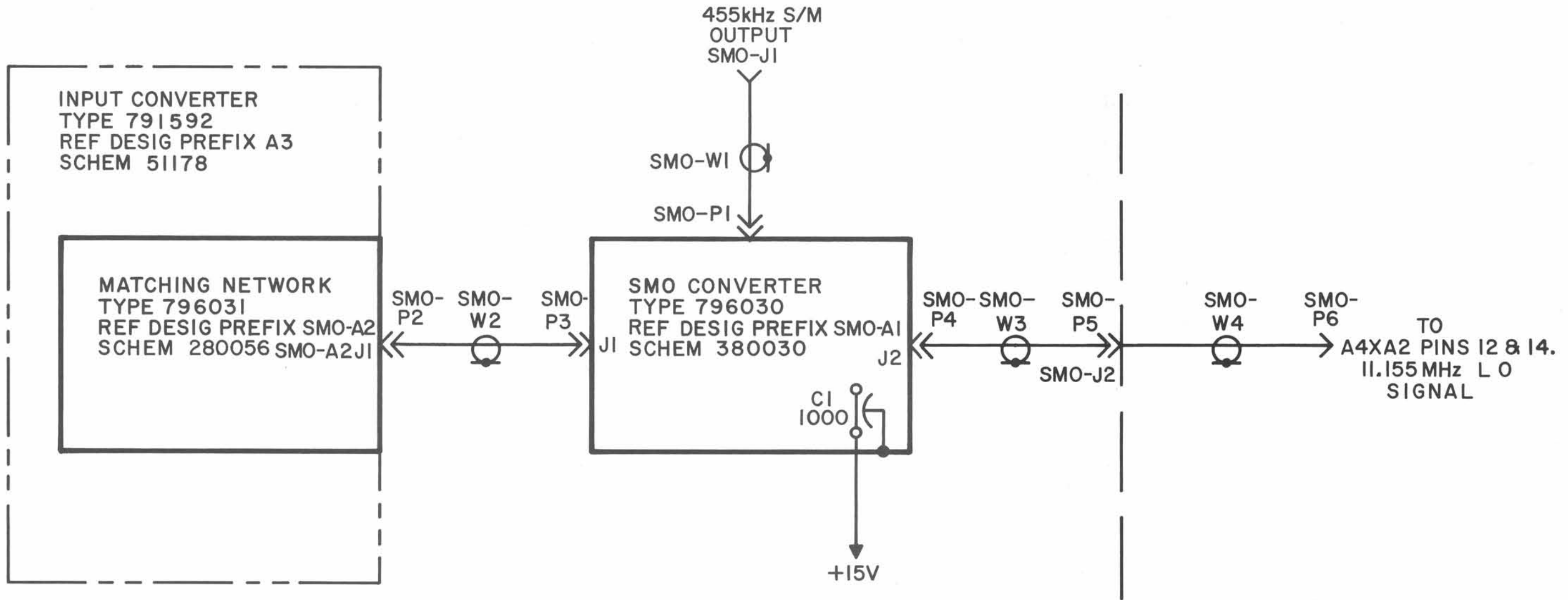

Figure 1-8. SMO Assembly Schematic Diagram 380027

July 20, 1979
ADDENDUM I

This addendum to the WJ-8718/SMO supplement identifies printed information which has since been revised due to changes in equipment nomenclature and engineering improvements in the existing circuitry. The revisions indicated below should be incorporated in all appropriate sections of the WJ-8718/SMO supplement.

REVISED INFORMATION

1) Change all WJ-8718/SMO subassembly reference designations in the text, parts list, and schematic drawings from A1, A1A1, and A2 to, respectively, SMO-A1, SMO-A1A1, and SMO-A2.

2) Page 1-2, paragraph 1.6.1; Delete printed paragraph and substitute the following:

"Figure 1-6 is the schematic drawing for this assembly. From the collector of A3A2Q4 (see Figure 1-7), the 20.7 MHz signal enters Matching Network SMO-A2. Components C1, C2, and L2 form a bandpass filter with a center frequency of 10.7 MHz. FL1 eliminates signal loading and provides additional gain on the 10.7 MHz output, J1. Selectivity of this network provides for 30 dB additional rejection of the 2nd LO signal."

3) Replace page 1-8 and foldout Figure 1-6 in the WJ-8718/SMO supplement with the corresponding revised pages.

1.8.2 TYPE 796031 MATCHING NETWORK ASSEMBLY

REF DESIG PREFIX A2

REF DESIG	DESCRIPTION	QTY. PER ASSY.	MANUFACTURER'S PART NO.	MFR. CODE	RECM. VENDOR
C1	Capacitor, Mica, Dipped: 62 pF, 2%, 500 V	1	CM05ED620G03	81349	72136
C2	Capacitor, Mica, Dipped: 110 pF, 2%, 500 V	1	CM05FD111G03	81349	72136
FL1	Filter, Ceramic	1	SFE-10.7MA-5	51406	
J1	Connector, Receptacle	1	10-0104-002	19505	
L1	Not Used				
L2	Coil, Fixed: 1.8 μ H, 10%	1	1537-18	99800	
RA1	Heatsink	1	TXB2P032-037B	98978	

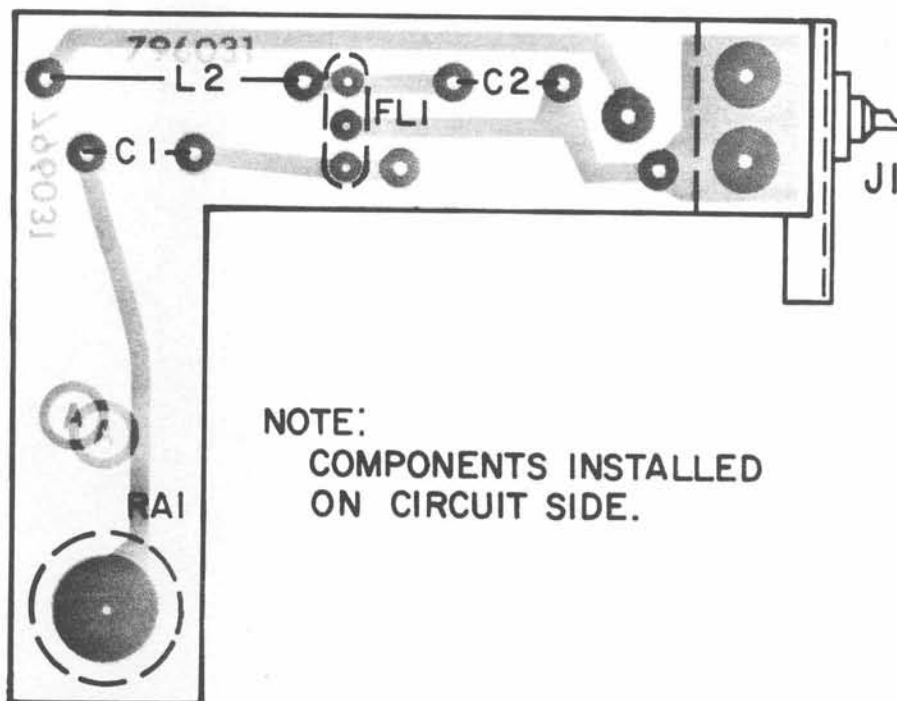

Figure 1-4. Type 796031 Matching Network Assembly (A2), Location of Components

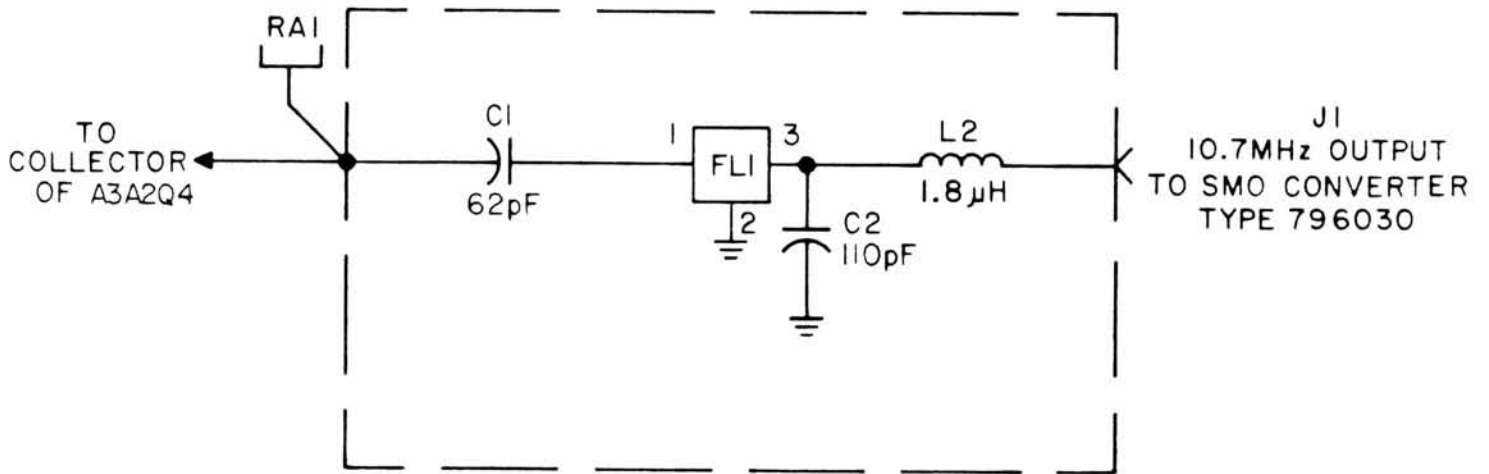

Figure 1-6. Type 796031 Matching Network (A2)
Schematic Diagram 280056